



Design Note

UCC3958 Demonstration Board Schematic and Bill of Materials

By David Salerno

The UCC3958 demo board is designed to provide complete over-charge, under-charge and over-load/short circuit protection for a single Lithium-ion cell. The schematic and parts list of the demo board are shown on the following page.

The over-current delay capacitor, CDLY, is optional and not installed on this demo board. The nominal internal over-current delay time of 360µsec is adequate for charging capacitive loads of up to 1000µF. If desired, the delay time can be extended by adding a small ceramic cap for CDLY. A graph of the over-current delay time as a function of cap value is given below.

Note that the bypass/energy storage capacitor (C1) supplied with the demo board is a 1µF tantalum.

This provides more than enough energy storage to power U1 during a shorted pack condition, even with an extended over-current delay time. If the delay time is not extended, a smaller value of capacitor can be used for C1.

For more complete information, pin descriptions and specifications for the UCC3958, please refer to the datasheet or contact your Unitrode Field Applications Engineer.

NOTE: The UCC3958 was designed to be connected directly to the Li-Ion cell, within the battery pack. When testing with more than 1" of wire between the power source and the demo board, it is strongly recommended that a bypass capacitor be placed across the cell connections on the demo board to minimize ringing under high peak current conditions.

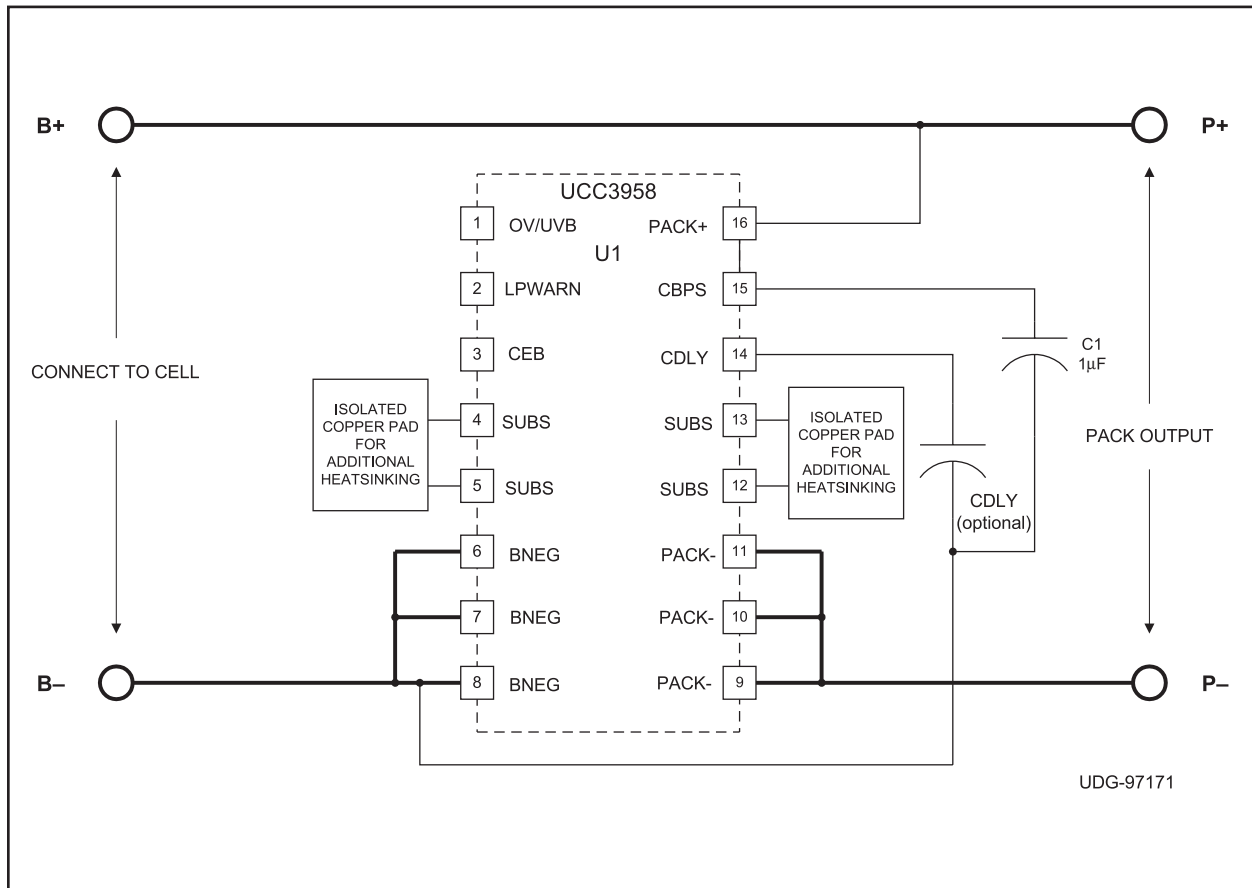

Figure 1. UCC3958 Demonstration Board Schematic

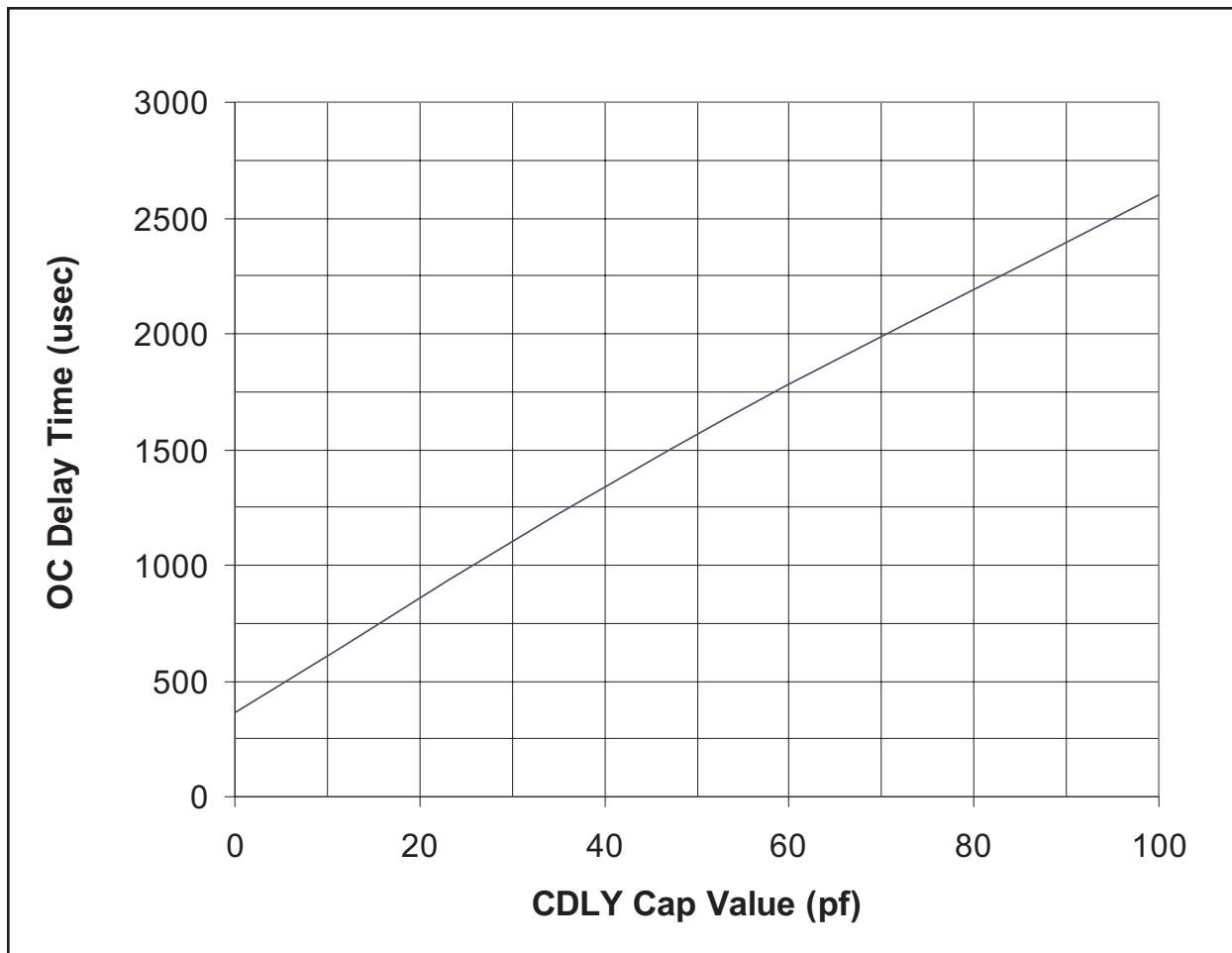

Figure 2. Nominal Overcurrent Delay Time vs. CDLY

Reference Designator	Part Description	Part Value	Manufacturer	Part Number
U1	Protector IC	Single cell Li-Ion	Unitrode	UCC3958
C1	Tantalum Capacitor	16V	Panasonic	ECS-T1CY105R
CDLY	Optional Ceramic Chip Capacitor	0603 Size		

Table 1. Demo Board Parts List